

## Mini-Horizontal System

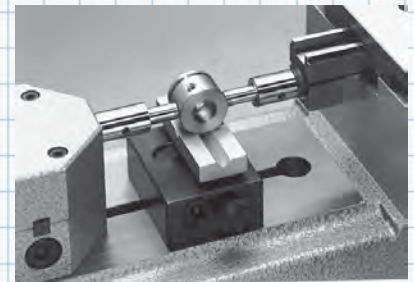

*Measurement of lengths and external diameters.*

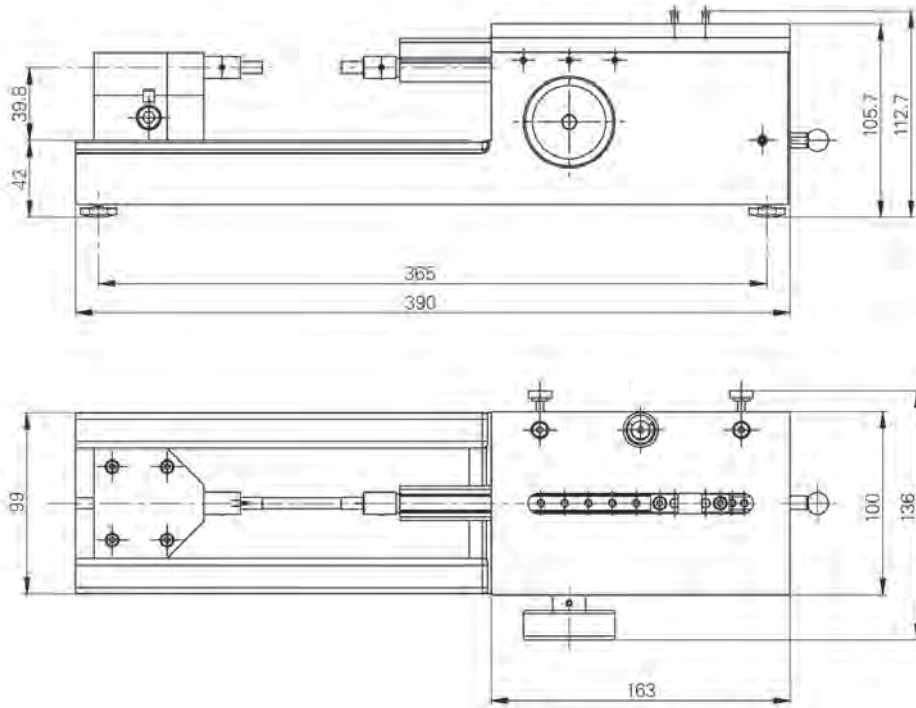
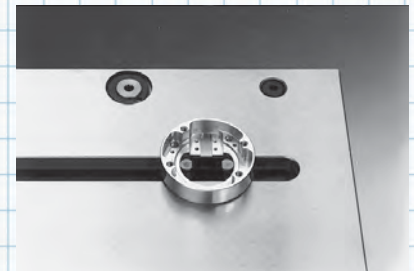

*Measurement of internal diameters, grooves and distances.*



Order Number	Description
Mini-Horizontal:	
53-190-012	Mini-Horizontal with internal support plates, standard internal & external probes.
Accessories:	
53-190-020	Std. replacement internal probe set. (2 pc.) Included w/unit.
53-190-029	Internal ball probe set. (2 pc.)
53-190-030	Internal groove probe set. (2 pc.)
53-190-031	Internal ball /flat probe set. (2 pc.)
53-190-036	Large ball probe. (2 pc.)
53-190-019	.256" std. replacement external probe set. (2 pc.) Included w/unit.
53-190-033	.315" large diameter external probe set. (2 pc.)
53-190-034	#4-48 thread external contact point holder (each)
53-190-032	M2.5 x .45 thread ext. contact point holder (each)
53-190-037	.080" flat carbide probe (each)
53-190-025	Adjustable H support with clearance
53-190-026	Adjustable support with crossed V-grooves
53-190-027	Adjustable support plate, plane
53-190-028	Locking adjustable base w/vertical adjustment for above supports
54-197-106	Floating measuring table
Bushings/Extensions:	
53-190-017	Bushing for AGD indicators to Mini-horizontal - with 3/8" bushing
53-190-018	Rack/extension for AGD indicators to 53-190-012 - with 4-48 thread.

See the section for probes and displays (page 121), and indicators (page 106).